



Features and Benefits

- ▶ Ultra-high capacitance aluminium oxide sensor delivers unsurpassed sensitivity, speed of response, accuracy, repeatability, stability, and long service life
- ▶ Unique Automatic Calibration (AutoCal) span correction feature
- ▶ Various dewpoint ranges available from -110 °C to +20 °C
- ▶ Compact 2-Wire 4-20 mA Loop Powered Dewpoint Transmitter
- ▶ Accuracy ± 2 °C dewpoint
- ▶ IP66 / NEMA 4 Weatherproof Protection Optional Sensor Holder/Sample Cell for optimum sampling conditions
- ▶ Supplied with a calibration certificate traceable to National and International Humidity standards



AMT Dewpoint Transmitter is a 2-wire 4-20 mA loop-powered transmitter that continuously measures moisture in process gas or compressed air. The 4-20 mA linear output signal can be factory configured for any of the following moisture units:- °C or °F dewpoint, ppm(V), ppb(V), g/m³, and lb/MMSCF.

At the heart of the AMT Dewpoint Transmitter is our ultra-high capacitance aluminium oxide sensor, which delivers unsurpassed sensitivity, speed of response, accuracy, repeatability, stability, and long service life. Every unit is supplied with a Calibration Certificate traceable to International Humidity Standards, guaranteeing accuracy to ± 2 °C dew point.

The unique Automatic Calibration (AutoCal) feature is standard on all AMT Transmitter models and allows the user to conduct span corrections to ensure optimum accuracy between laboratory calibrations. AutoCal is operated using two small buttons on the side of the body.

AMT is designed to withstand a maximum pressure of 35,000 kPa (350 bar) and extreme environmental conditions. The rugged stainless steel construction provides protection to IP66 / NEMA 4X.

The AMT Transmitter is extremely easy to install and operate, requiring little or no maintenance. The advanced DS4000 or the standard DS1200 Hygrometers can display dewpoint in a range of units up to 1000 meters from the AMT Transmitter with the appropriate cable.

AMT - Dewpoint Transmitter Technical Data

Transmitter Type	2-Wire 4-20 mA Loop Powered Dewpoint Transmitter
Sensing Element	Ultra-High Capacitance – Aluminium Oxide Type
Output Signal	Linear 4-20 mA with selectable engineering units and fault indication
Power Supply	12-28 Vdc Reverse Polarity Protected
Dewpoint Ranges	Between -120 °C to +20 °C (-184 °F to +68 °F) dewpoint. See How to Order on page 3
Electromagnetic Compatibility (EMC)	Complies with BS EN ICE 61326-1
Accuracy	± 2 °C dewpoint (UK National Physical Laboratory traceable for range -90 °C to +20 °C)
Repeatability	Better than ± 0.3 °C dewpoint
Operating Temperature (Ambient and Process)	-20 °C to 60 °C
Operating Pressure (Process)	From 1 kPa (0.01 bara) to Maximum 35,000 kPa (350 bara)
Operating Humidity (Ambient)	Maximum 95 %RH Non-Condensing
Storage Temperature	-20 °C to 70 °C
Field Calibration	AutoCal span check and correction are performed using two buttons on the Transmitter body. Locked in normal operating mode to avoid tamper. We recommend AutoCal is repeated every 2-3 months.

Factory Calibration	Supplied with a calibration certificate traceable to National and International Humidity standards. We recommend annual laboratory calibration
Sample Flow Rate	Flow independent but ideally 2 to 5 litres per minute. Max: 25 litres/min
Cable Terminations	IP66 / NEMA 4X rated, size C, DIN EN 175301 connector at the Transmitter and other end terminated with bootlace ferrules
Cable	Supplied with 2m standard cable. Nominal diameter 3.4 mm, 92 ohms/km at 20 °C
Mechanical Connection	3/4" UNF (16tpi) with integral Viton "O" ring seal
Isolation	Sensing Element connected to the 4-20 mA loop but isolated from Transmitter body
Transmitter Body	316 Stainless Steel
Sensor Protection	316 Sintered Stainless Steel Filter – 50 micron
Probe Material (Wetted Parts)	316 Stainless Steel
Ingress Protection	IP66 / NEMA 4X when Connector coupled to Transmitter
Manufacturer's Warranty	24 months in case of defective parts or faulty workmanship

Dimensions

AMT Transmitter

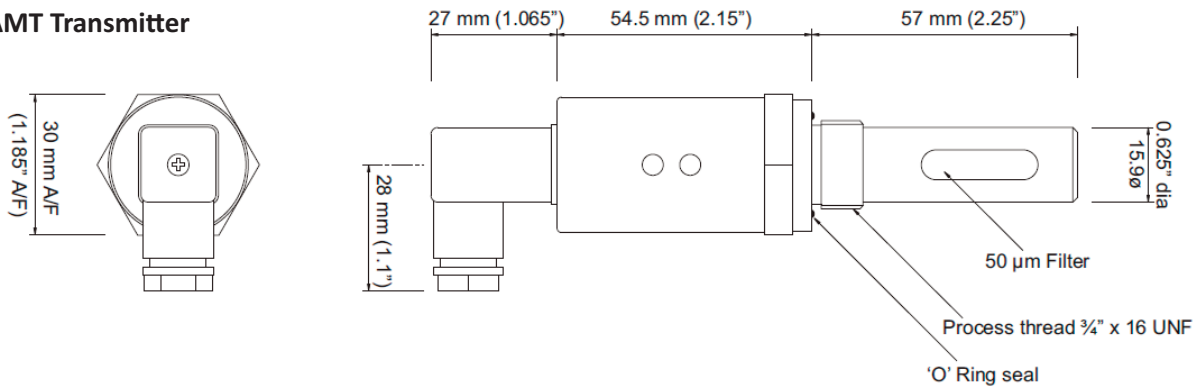

SH-AMT Transmitter Holder

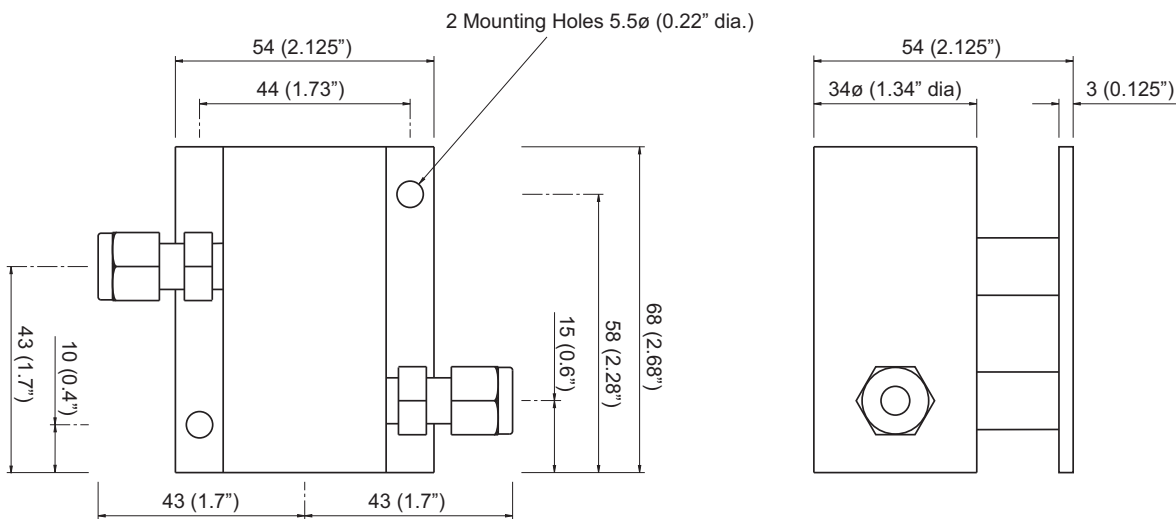

Note: The Assembly is shown with 1/4" @ OD tube fittings. The dimensions across the tube fittings will vary for all other size fittings.

DS4000 Hygrometer Display Technical Specifications - See Datasheet - Document No. 3037

DS1200 Hygrometer Display Technical Specifications - See Datasheet - Document No. 3039

How to order

1 Transmitter Range: AMT- [XX]

Range/Unit -	Dewpoint	
-120 °C to +20 °C (-184 °F to +68 °F) R = 0.1 °C/°F		LD
-110 °C to -20 °C (-166 °F to -4 °F) R = 0.1 °C/°F		SR
-100 °C to 0 °C (-148 °F to +32 °F) R = 0.1 °C/°F		PL
-100 °C to +20 °C (-148 °F to +68 °F) R = 0.1 °C/°F		SD
-80 °C to -20 °C (-112 °F to -4 °F) R = 0.1 °C/°F		RD
-80 °C to 0 °C (-112 °F to +32 °F) R = 0.1 °C/°F		GY
-65 °C to +20 °C (-85 °F to +68 °F) R = 0.1 °C/°F		HD
ppm(V)		
1 to 1000	R = 1ppm	SP
0.1 to 100.0	R = 0.1ppm	MP
0.01 to 10.00	R = 0.01ppm	LP
ppb(V)		
1 to 1000	R = 1ppb	PB
g/m³		
0.01 to 10.00	R = 0.01 g/m ³	HG
0.001 to 1.000	R = 0.001 g/m ³	LG
lbs/MMSCF		
0.1 to 100.0	R = 0.1 lbs/MMSCF	LB
R = Resolution		

NOTE: ppm, ppb, g/m³ & lbs/MMSCF ranges are stated at atmospheric pressure. AMT Transmitter can be configured to provide corresponding ranges for operation at other constant pressure. This must be stated at time of order.

2 Cable: CAB069-AMT + [XX]

The AMT Transmitter comes complete with 2 metres of connecting cable and connector plug as standard.



For a longer cable length with connecting plug, simply enter the required length after the part number above:

Example: CAB069-AMT-[10] for 10 metres.
Longer cables are charged at per meter increments up to 1000 metres.

4 Display:



DS4000

Advanced Display with more functions and features



DS1200

Standard Display

- Located in the Safe Area only
- Both displays are perfect for continuous on-line measurements with the AMT Dewpoint Transmitter
- Fast Response
- Single channel on-line hygrometer
- 2 independent alarms
- 4-20 mA re-transmission

For full specifications see DS4000 & DS1200 datasheets

3 Transmitter Holder with Fittings SH-AMT + [X][X]

- Comes complete with mounting plate.



INLET Pipe Fitting

No Fittings	0
1/4" - Pipe OD	4
1/8" - Pipe OD	8
6 mm - Pipe OD	6

OUTLET Pipe Fitting

No Fittings	0
1/4" - Pipe OD	4
1/8" - Pipe OD	8
6 mm - Pipe OD	6

NOTE: No Fittings Needed = Ports are 1/8" NPT Female

Example: For Transmitter Holder with 2 x 1/4" fittings
Order SH-AMT-4-4

Corrosive Gases: The Sensor should not be exposed to corrosive gases (or corrosive contaminants in the gas sample) as these can chemically attack the sensor, impairing calibration accuracy and/or damaging it beyond economic repair. Examples of such gases are mercury (Hg), ammonia (NH₃), chlorine (Cl₂) etc. Strong oxidising agents such as ozone (O₃) should also be prevented from coming into contact with the sensor.

Recommended Related Products

Custom-Compact Sampling Systems based on the DS4000-AMT Hygrometer System



Custom-Compact Sampling Systems based on the DS1200-AMT Hygrometer System



1869 AMT-Ex pd120123-Iss-8

Alpha Moisture Systems Limited.
Registered Office: Alpha House,
96 City Road, Bradford, BD8 8ES. UK.



Registered in England and Wales No. 3902302
VAT Registration No. GB607207563
WEEE Producer Registration No. WEEE/EA0067TX

Tel +44 (0) 1274 733100

Email info@amsystems.co.uk

Website www.amsystems.co.uk

Product specification may be subject to change.

© Alpha Moisture Systems Ltd.

3/3